

Specifications	Model	TP-6000	Tauris TP-601D	Hector TP-705	Atlantis TP-701
Strap Width		8 mm-15.5 mm	8 mm-12 mm	5 mm, 6 mm	5 mm, 6 mm, and 9 mm
Strap Tension		10-70 kg	7-70 kg	5-28 kg	1-35 kg
Speed (straps/minute, 60Hz)		27	29	28	50
Net Weight		220 kg	220 kg	125 kg	150 kg
Power		110V, 220V, 230V, 380V, 415V 50/60Hz 1PH or 3PH	110V, 220V, 230V, 380V, 415V 50/60Hz 1PH or 3PH	110V, 220V, 230V 50/60Hz 1PH	110V, 220V, 230V 50/60Hz 1PH

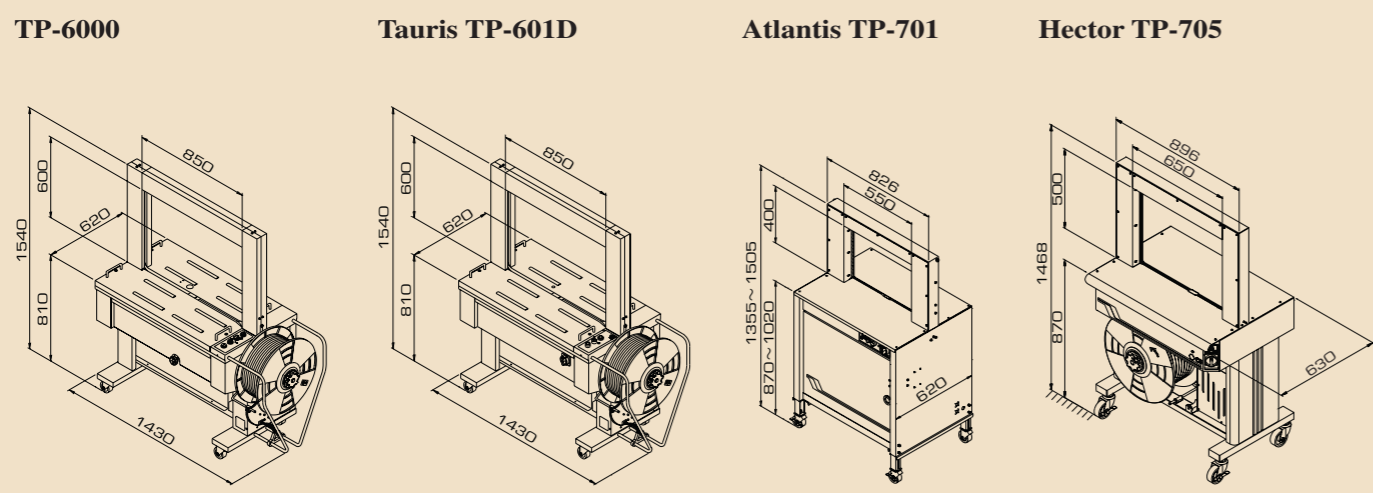

TP-6000/TP-601D Arch Sizes:

H	W	650	850	1050	1250
400					
600			(S)		
800					
1000					
1200					

(S) Standard size: 850 mm(W) x 600 mm(H)
 • Larger arches are available on request

TP-701 Arch Sizes:

H	W	550	650	850	1050	1250	1650
300			✓				
400		(S)		✓			
500			✓	✓		✓	✓
600			✓	✓			
800			✓	✓	✓	✓	
1000				✓	✓	✓	

(S) Standard size: 550 mm(W) x 400 mm(H)
 • Arch sizes available with mark (✓)

TP-705 Arch Sizes:

• Standard size: 650 mm(W) x 500 mm(H)

All specifications subject to change without notice.



9F-4, NO.112, SEC. 2, CHUNG SHAN N. ROAD, TAIPEI 104, TAIWAN
 MAILING ADDRESS : P.O.BOX 68-1951, TAIPEI 104, TAIWAN
 TEL : (02) 2581 0126 FAX : 886 2 2562 9849
 WEB : www.transpakcorp.com E-mail : transpak@transpak.com.tw

05.2006x2000

AUTOMATIC STRAPPING MACHINE

Transpak offers general-purpose automatic strapping machines with reliability and high performance. In this category, we have from conventional model to world-class innovative high-speed model as follows:

- Conventional model for wide straps **TP-6000**
- Enhanced model for wide straps **Tauris TP-601D**
- Economy model for narrow straps **Hector TP-705**
- High-speed world-class model for narrow straps **Atlantis TP-701**

Different machines with different prices and features can meet your various budgets and needs.

TP-601D



For Wide Straps (8 mm-15.5 mm)



TAURIS TP-601D

Enhanced machine, the most powerful machine in its class

Main Enhancements:

- ▶ **Auto Strap Feeding**
Simply insert the strap into the feeding rollers from the coil side of the machine and then push the "reset" button. Easy strap loading.
- ▶ **Electronic Tension Control**
External adjustment of strap tension by the simple turn of a dial. Easy operation.
- ▶ **Auto Strap Ejector**
Loop-eject clears unwanted strap automatically, if the machine is accidentally strapped without a package. Eliminates downtime.

More Features:

- ▶ **Short Feed Sensor**
- ▶ **Auto Strap Refeed**
- ▶ **Strap End Ejector**

Options

- ▶ Stainless steel frame SUS 304
- ▶ TP-601L Low table model for heavy and bulky packages



TP-6000

Conventional machine, an economy model

Main Features:

- ▶ Easy operation, simple maintenance.
- ▶ Mechanical outside tension control. Tension can be easily set with a dial.
- ▶ Affordable for every budget.

Options

- ▶ Stainless steel frame SUS 304
- ▶ Short feed sensor

For Narrow Straps (5 mm- 9 mm)



ATLANTIS TP-701

A world-class model for narrow straps, 50 straps per minute

Main Features:

- ▶ **Compact Mechanical Control Head**
With 30% fewer parts than comparable strapping machines, Atlantis requires fewer adjustments, and requires less maintenance.
- ▶ **Auto Strap Feeding**
Simply insert the strap into the feeding rollers, push the start switch and the machine will automatically feed itself. Easy strap loading.
- ▶ **Electronic Tension Control**
External adjustment of strap tension by the simple turn of a dial. Easy operation.
- ▶ **Auto Strap Ejector**
Loop-eject clears unwanted strap automatically, if the machine is accidentally strapped without a package. Eliminates downtime.
- ▶ **Adjustable Table Height**
Between 870 mm and 1020 mm.

Options

- ▶ With press bar (TP-701P)
- ▶ Stainless steel frame SUS 304
- ▶ Photo-eye switch for cycle initiation
- ▶ Foot bar switch for cycle initiation

(See individual catalogue for more details of TP-701 and TP-701P)



Hector TP-705

Economy model

Main Features:

- ▶ **Compact Mechanical Control Head**
With less moving parts substantially reduces maintenance issues.
- ▶ **Electronic Tension Control**
Adjustment of strap tension by the simple turn of a dial. Easy operation.
- ▶ **Auto Strap Ejector**
Loop-eject clears unwanted strap automatically, if the machine is accidentally strapped without a package. Eliminates downtime.

Options

- ▶ Foot pedal switch
- ▶ Adjustable table height between 870 mm and 950 mm